

Q. No. 1 – 5 Carry One Mark Each

1. Which of the following options is the closest in meaning to the word underlined in the sentence below?

In a democracy, everybody has the freedom to disagree with the government.

- (A) dissent (B) descent (C) decent (D) decadent

Answer: (A)

2. After the discussion, Tom said to me, 'Please revert!' He expects me to _____.

- (A) retract (B) get back to him
(C) move in reverse (D) retreat

Answer: (B)

3. While receiving the award, the scientist said, "I feel vindicated". Which of the following is closest in meaning to the word 'vindicated'?

- (A) punished (B) substantiated (C) appreciated (D) chastened

Answer: (B)

4. Let $f(x, y) = x^n y^m = P$. If x is doubled and y is halved, the new value of f is

- (A) $2^{n-m} P$ (B) $2^{m-n} P$ (C) $2(n-m)P$ (D) $2(m-n)P$

Answer: (A)

Exp. $P' = 2^n X^n \left(\frac{1}{2}\right)^m y^m$
 $= 2^{n-m} X^n Y^m = 2^{n-m} P$

5. In a sequence of 12 consecutive odd numbers, the sum of the first 5 numbers is 425. What is the sum of the last 5 numbers in the sequence?

Answer: 495

Exp. 8th observation is $7 \times 2 = 14$ more than 1st observation

9th observation is 14 more than 2nd observation

10th observation is 14 more than 3rd observation

11th observation 14 more than 4th observation

12th observation 14 more than 5th observation

Total $14 \times 5 = 70$

Sum of the first five numbers = 425

Sum of last five numbers = 495

Q. No. 6 – 10 Carry Two Marks Each

6. Find the next term in the sequence: 13M, 17Q, 19S, ___
 (A) 21W (B) 21V (C) 23W (D) 23V

Answer: (C)

7. If 'KCLFTSB' stands for 'best of luck' and 'SHSWDG' stands for 'good wishes', which of the following indicates 'ace the exam'?
 (A) MCHTX (B) MXHTC (C) XMHCT (D) XMHTC

Answer: (B)

Exp. KCLFTSB: BST-Best, F-Of, LCK-Luck (Reverse order)
 SHSWDG: GD-Good, WSHS-Wishes (Reverse order)
 Similarly "ace the Exam"- C-Ace, T-The, XM-Exam

8. Industrial consumption of power doubled from 2000-2001 to 2010-2011. Find the annual rate of increase in percent assuming it to be uniform over the years.
 (A) 5.6 (B) 7.2 (C) 10.0 (D) 12.2

Answer: (B)

9. A firm producing air purifiers sold 200 units in 2012. The following pie chart presents the share of raw material, labour, energy, plant & machinery, and transportation costs in the total manufacturing cost of the firm in 2012. The expenditure on labour in 2012 is Rs. 4,50,000. In 2013, the raw material expenses increased by 30% and all other expenses increased by 20%. What is the percentage increase in total cost for the company in 2013?

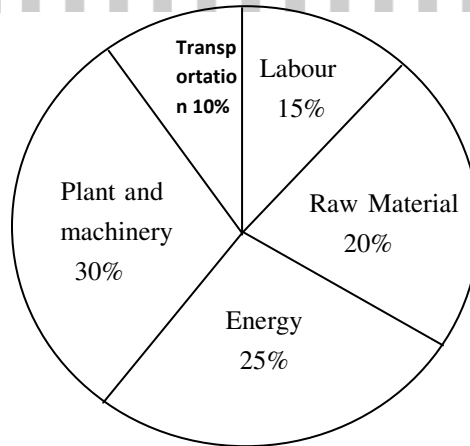

Answer: 22

Exp.

	2012	2013
Transport (10%)	300,000	360,000
Labour (15%)	450,000	540,000
Raw material (20%)	750,000	780,000
Energy (25%)	750,000	900,000
Plant and Machinery (30%)	900,000	1,080,000
Total	3,000,000	3,660,000

Percentage increase in total cost = 22%

10. A five digit number is formed using the digits 1,3,5,7 and 9 without repeating any of them. What is the sum of all such possible five digit numbers?
- (A) 6666660 (B) 6666600 (C) 6666666 (D) 6666606

Answer: (B)

Exp. The digit in unit place is selected in 4! Ways

The digit in tens place is selected in 4! Ways

The digit in hundreds place is selected in 4! Ways

The digit in thousands place is selected in 4! Ways

The digit in ten thousands place is selected in 4! Ways

Sum of all values for 1

$$4! \times 1 \times (10^0 + 10^1 + 10^2 + 10^3 + 10^4)$$

$$= 4! \times 11111 \times 1$$

Similarly for '3' $4! \times (11111) \times 3$

Similarly for '5' $4! \times (11111) \times 5$

Similarly for '7' $4! \times (11111) \times 7$

Similarly for '9' $4! \times (11111) \times 9$

$$\therefore \text{sum of all such numbers} = 4! \times (11111) \times (1 + 3 + 5 + 7 + 9)$$

$$= 24 \times (11111) \times 25 = 6666600$$

Solution is $y(IF) = \int Q(IP) dx + C$

$$ye^{x^2} = 0 + C$$

$$\therefore y = Ce^{-x^2}$$

Given $y(0) = 2 \Rightarrow 2 = C$

$$\therefore y = 2e^{-x^2}$$

4. A nationalized bank has found that the daily balance available in its savings accounts follows a normal distribution with a mean of Rs. 500 and a standard deviation of Rs. 50. The percentage of savings account holders, who maintain an average daily balance more than Rs 500 is _____

Answer: 49 to 51

Exp: Given $M = 500$

$$\sigma = 50$$

$$P(X > 500) = ?$$

Where X follows normal distribution

We know that standard normal variable

$$z = \frac{x - M}{\sigma}$$

$$z = \frac{500 - 500}{50} = 0$$

$$\therefore P(X > 500) = P(z > 0) = 0.50 \text{ (see figure)}$$

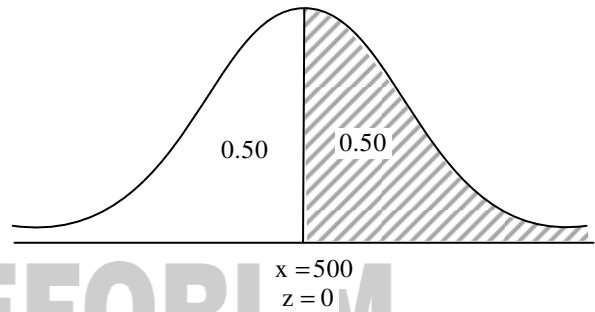

5. Laplace transform of $\cos(\omega t)$ is $\frac{s}{s^2 + \omega^2}$. The laplace transform of $e^{-2t} \cos(4t)$ is

(A) $\frac{s-2}{(s-2)^2 + 16}$

(B) $\frac{s+2}{(s-2)^2 + 16}$

(C) $\frac{s-2}{(s+2)^2 + 16}$

(D) $\frac{s+2}{(s+2)^2 + 16}$

Answer: (D)

Exp: We know that if $L\{f(t)\} = F(s)$

$$\text{Then } L\{e^{at} f(t)\} = F(s-a)$$

$$\begin{aligned} \therefore L\{e^{-2t} \cos 4t\} &= \frac{s+2}{(s+2)^2 + 4^2} \\ &= \frac{s+2}{(s+2)^2 + 16} \end{aligned}$$

6. In a statically determinate plane truss, the number of joints (j) and the number of members (m) are related by
(A) $j = 2m - 3$ (B) $m = 2j + 1$ (C) $m = 2j - 3$ (D) $m = 2j - 1$

Answer: (C)

7. If the Poisson's ratio of an elastic material is 0.4, the ratio of modulus of rigidity to Young's modulus is _____

Answer: 0.35 to 0.36

Exp: From $E=2G(1+\mu)$

$$\frac{G}{E} = \frac{1}{2(1+\mu)} = \frac{1}{2(1+0.4)} = 0.357$$

8. Which one of the following is used to convert a rotational motion into a translational motion?
(A) Bevel gears (B) Double helical gears
(C) Worm gears (D) Rack and pinion gears

Answer: (D)

9. The number of independent elastic constants required to define the stress-strain relationship for an isotropic elastic solid is _____

Answer: 1.9 to 2.1

10. A point mass is executing simple harmonic motion with an amplitude of 10 mm and frequency of 4 Hz. The maximum acceleration (m/s^2) of the mass is _____

Answer: 6.3 to 6.4

Exp: Given $A=10 \text{ mm}=0.01 \text{ m}$

$$f=4\text{Hz}$$

$$x=A\cos\omega t$$

$$v = \frac{dx}{dt} = -A\omega \sin \omega t$$

$$\frac{d^2x}{dt^2} = a = -A\omega^2 \cos \omega t$$

For maximum, $t=0$

$$\therefore a = A\omega^2 = 0.01(2\pi f)^2$$

$$\therefore \omega = 2\pi f = 0.01(2 \times \pi \times 4)^2 = 6.32 \text{ m/s}^2$$

11. Ball bearings are rated by a manufacturer for a life of 10^6 revolutions. The catalogue rating of a particular bearing is 16 kN. If the design load is 2 kN, the life of the bearing will be $p \times 10^6$ revolutions, where p is equal to _____

Answer: 500 to 540

15. Match Group A with Group B:

Group A	Group B
P: Biot number	1: Ratio of buoyancy to viscous force
Q: Grashof number	2: Ratio of inertia force to viscous force
R: Prandtl number	3: Ratio of momentum to thermal diffusivities
S: Reynolds number	4: Ratio of internal thermal resistance to boundary layer thermal resistance

(A) P-4, Q-1, R-3, S-2

(B) P-4, Q-3, R-1, S-2

(C) P-3, Q-2, R-1, S-4

(D) P-2, Q-1, R-3, S-4

Answer: (A)

16. Kaplan water turbine is commonly used when the flow through its runner is

(A) axial and the head available is more than 100 m

(B) axial and the head available is less than 10 m

(C) radial and the head available is more than 100 m

(D) mixed and the head available is about 50 m

Answer: (B)

Exp: Kaplan turbine is an axial flow turbine and works at low heads (<50).

17. Moist air at 35°C and 100% relative humidity is entering a psychrometric device and leaving at 25°C and 100% relative humidity. The name of the device is

(A) Humidifier

(B) Dehumidifier

(C) Sensible heater

(D) Sensible cooler

Answer: (B)

Exp:

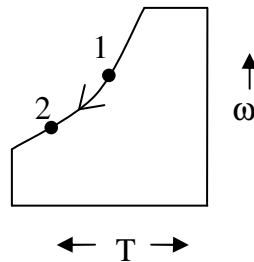

Since water content in moist air is reducing. The device is de-humidifier.

18. The total number of decision variables in the objective function of an assignment problem of size $n \times n$ (n jobs and n machines) is

(A) n^2

(B) $2n$

(C) $2n - 1$

(D) n

Answer: (A)

Exp: A, $n \times n$ assignment problem, if it is solved as a LPP it will have n^2 variables.

23. Better surface finish is obtained with a large rake angle because
- (A) the area of shear plane decreases resulting in the decrease in shear force and cutting force
 - (B) the tool becomes thinner and the cutting force is reduced
 - (C) less heat is accumulated in the cutting zone
 - (D) the friction between the chip and the tool is less

Answer: (A)

24. Match the heat treatment processes (Group A) and their associated effects on properties (Group B) of medium carbon steel:

Group A	Group B
P: Tempering	I: Strengthening and grain refinement
Q: Quenching	II: Inducing toughness
R: Annealing	III: Hardening
S: Normalizing	IV: Softening

- (A) P-III, Q-IV, R-II, S-I
- (B) P-II, Q-III, R-IV, S-I
- (C) P-III, Q-II, R-IV, S-I
- (D) P-II, Q-III, R-I, S-IV

Answer: (B)

25. In a rolling process, the maximum possible draft, defined as the difference between the initial and the final thickness of the metal sheet, mainly depends on which pair of the following parameters
- P: Strain
 - Q: Strength of the work material
 - R: Roll diameter
 - S: Roll velocity
 - T: Coefficient of friction between roll and work
- (A) Q, S
 - (B) R, T
 - (C) S, T
 - (D) P, R

Answer: (B)

Q. No. 26 – 55 Carry Two Marks Each

26. If z is a complex variable, the value of $\int_5^{3i} \frac{dz}{z}$ is
- (A) $-0.511-1.57i$
 - (B) $-0.511+1.57i$
 - (C) $0.511-1.57i$
 - (D) $0.511+1.57i$

Answer: (B)

Exp: $\int_5^{3i} \frac{dz}{z} = \ln(z) \Big|_5^{3i}$

$$= \ln 3i - \ln 5 = \ln 3 + i \frac{\pi}{2} - (\ln 5 + i0)$$

$$\left[\therefore \ln z = \ln r + i\theta \text{ where } r = \sqrt{x^2 + y^2}, \theta = \arg z \right]$$

$$= \ln 3 - \ln 5 + i \frac{22}{14} = -0.511 + 1.57i$$

27. The value of integral $\int_0^2 \int_0^x e^{x+y} dy dx$ is

- (A) $\frac{1}{2}(e-1)$ (B) $\frac{1}{2}(e^2-1)^2$ (C) $\frac{1}{2}(e^2-e)$ (D) $\frac{1}{2}\left(e-\frac{1}{e}\right)^2$

Answer: (B)

Exp. $\int_0^2 \int_0^x e^{x+y} dy dx = \int_0^2 e^x \left(\int_0^x e^y dy \right) dx$

$$= \int_0^2 e^x (e^y)_0^x dx = \int_0^2 e^x (e^x - 1) dx$$

$$= \int_0^2 (e^{2x} - e^x) dx = \left(\frac{e^{2x}}{2} - e^x \right)_0^2$$

$$= \frac{e^4}{2} - e^2 - \frac{1}{2} + 1 = \frac{e^4}{2} - e^2 + \frac{1}{2}$$

$$= \frac{1}{2}(e^4 - 2e^2 + 1) = \frac{1}{2}(e^2 - 1)^2$$

28. The number of accidents occurring in a plant in a month follows Poisson distribution with mean as 5.2. The probability of occurrence of less than 2 accidents in the plant during a randomly selected month is

- (A) 0.029 (B) 0.034 (C) 0.039 (D) 0.044

Answer: (B)

Exp: Given $\lambda = 5.2$

Let x be random variable which follows Poisson's distribution

$$P(x < 2) = P(x=0) + P(x=1)$$

$$= \frac{e^{-\lambda} \lambda^0}{0!} + \frac{e^{-\lambda} \lambda^1}{1!} = e^{-5.2} (6.2) = 0.0055 \times 6.2 = 0.034$$

29. Consider an ordinary differential equation $\frac{dx}{dt} = 4t + 4$. If $x = x_0$ at $t = 0$, the increment in x calculated using Runge-Kutta fourth order multi-step method with a step size of $\Delta t = 0.2$ is

- (A) 0.22 (B) 0.44 (C) 0.66 (D) 0.88

Answer: (D)

Exp: Given $\frac{dx}{dt} = 4t+4$ $x = x_0$ at $t = 0$
 $n = 0.2$

Calculate $x(0.2)$ value

$$K_1 = f(t_0, x_0) = f(0, x_0) = 4$$

$$K_2 = f\left(t_0 + \frac{h}{2}, x_0 + \frac{1}{2} K_1 h\right)$$

$$= f(0+0.1, x_0+0.4) = f(0.1, x_0+0.4) = 4(0.1) + 4 = 4.4$$

$$K_3 = f\left(x_0 + \frac{h}{2}, x_0 + \frac{K_2 h}{2}\right)$$

$$= f(t_0+0.1, x_0+(2.2)(0.2)) = f(0.1, x_0+0.44) = 4(0.1) + 4 = 4.4$$

$$K_4 = f(t_0+h, x_0+K_3h)$$

$$= f(0+0.2, x_0+0.88) = f(0.2, x_0+0.88) = 4(0.2) + 4 = 4.8$$

$$x(0.2) = x_1 = x_0 + \frac{h}{6} (K_1 + 2K_2 + 2K_3 + K_4)$$

$$= x_0 + \frac{0.2}{6} (4 + 2(4.4) + 2(4.4) + (4.8))$$

$$= x_0 + \frac{0.2}{6} (4 + 2(4.4) + 2(4.4) + (4.8))$$

$$= x_0 + \frac{0.2}{6} (4 + 8.8 + 8.8 + 4.8) = x_0 + 0.88$$

$$\text{Increment as } x = x_1 - x_0 = x_0 + 0.88 - x_0 = 0.88$$

30. A shaft is subjected to pure torsional moment. The maximum shear stress developed in the shaft is 100 MPa. The yield and ultimate strengths of the shaft material in tension are 300 MPa and 450 MPa, respectively. The factor of safety using maximum distortion energy (von-Mises) theory is _____

Answer: 1.7 to 1.8

Exp: $\tau_{\max} = \frac{\sigma_u}{2\text{FOS}}$

$$\Rightarrow \text{FOS} = \frac{300}{2 \times 100} = 1.5$$

31. A thin gas cylinder with an internal radius of 100 mm is subject to an internal pressure of 10 MPa. The maximum permissible working stress is restricted to 100 MPa. The minimum cylinder wall thickness (in mm) for safe design must be _____

Answer: 9.8 to 10.6

Exp: $\sigma_1 = \frac{pd}{2t} \Rightarrow 100 = \frac{10 \times 2 \times 100}{2 \times t} \Rightarrow t = 10 \text{ mm}$

32. For the truss shown in the figure, the forces F_1 and F_2 are 9 kN and 3 kN, respectively. The force (in kN) in the member QS is

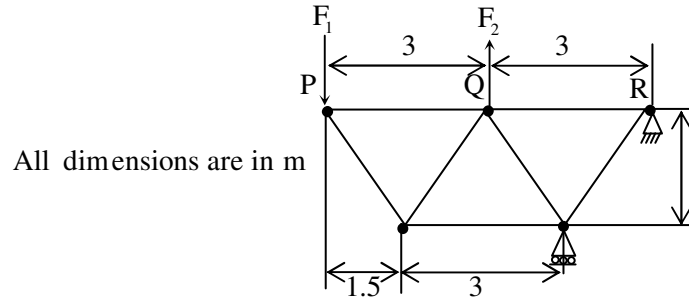

- (A) 11.25 tension (B) 11.25 compression
(C) 13.5 tension (D) 13.5 compression

Answer: (A)

Exp: By method of sections

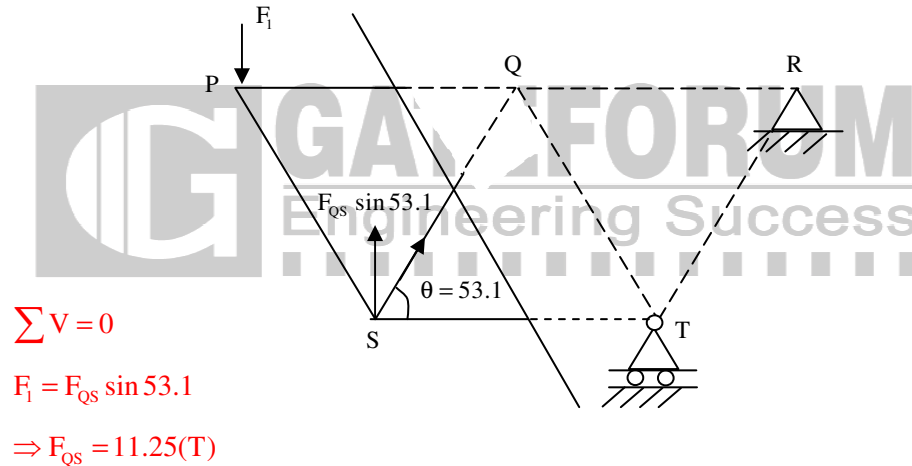

33. It is desired to avoid interference in a pair of spur gears having a 20° pressure angle. With increase in pinion to gear speed ratio, the minimum number of teeth on the pinion

- (A) increases (B) decreases
(C) first increases and then decreases (D) remains unchanged

Answer: (A)

34. A uniform slender rod (8 m length and 3 kg mass) rotates in a vertical plane about a horizontal axis 1 m from its end as shown in the figure. The magnitude of the angular acceleration (in rad/s^2) of the rod at the position shown is _____

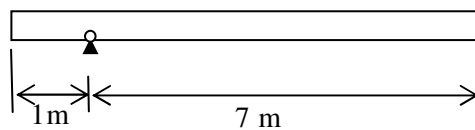

Answer: 1.9 to 2.1

35. A bolt of major diameter 12 mm is required to clamp two steel plates. Cross sectional area of the threaded portion of the bolt is 84.3 mm^2 . The length of the threaded portion in grip is 30 mm, while the length of the unthreaded portion in grip is 8 mm. Young's modulus of material is 200 GPa. The effective stiffness (in MN/m) of the bolt in the clamped zone is _____

Answer: 460 to 470

Exp: $d_1 = 12 \text{ mm}$;

$$l_1 = 8 \text{ mm}$$

$$A_2 = 84.33 \text{ mm}^2$$

$$A_1 = \frac{\pi}{4} (d_1)^2$$

$$A_2 = 84.33 \text{ mm}^2$$

$$l_2 = 30 \text{ mm}$$

$$K_1 = \frac{A_1 E_1}{l_1}; K_2 = \frac{A_2 E_2}{l_2} = \frac{84.33 \times 200}{30} = 562.2$$

$$= \frac{\frac{\pi}{4} (12)^2 \times 200}{8} = 2827.4$$

$$\frac{1}{K} = \frac{1}{K_1} + \frac{1}{K_2} = \frac{1}{2827.4} + \frac{1}{562.2}$$

$$\Rightarrow K = 468.9 \text{ MN / m}$$

36. A frame is subjected to a load P as shown in the figure. The frame has a constant flexural rigidity EI. The effect of axial load is neglected. The deflection at point A due to the applied load P is

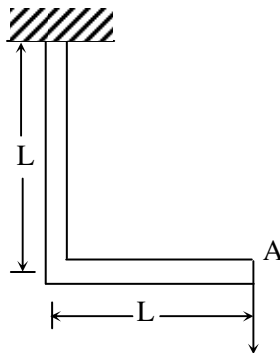

(A) $\frac{1}{3} \frac{PL^3}{EI}$

(B) $\frac{2}{3} \frac{PL^3}{EI}$

(C) $\frac{PL^3}{EI}$

(D) $\frac{4}{3} \frac{PL^3}{EI}$

Answer: (D)

Exp: Strain energy (E) = $\int_0^L \frac{M_x^2 dx}{2EI} + \int_0^L \frac{M_y^2 dx}{2EI}$

$M_x = PX \quad M_y = PL$

$\frac{1}{2} P\delta = \int_0^L \frac{(PX)^2 dx}{2EI} + \int_0^L \frac{(PL)^2 dx}{2EI}$

$$= \frac{P^2 \left[\frac{X^3}{6} \right]_0^L}{EI} + \frac{P^2 L^2}{2EI} [X]_0^L = \frac{2 P^2 L^3}{3 EI} = \frac{1}{2} \times P \times \frac{4 PL^3}{3 EI}$$

$$\delta = \frac{4 PL^3}{3 EI}$$

37. A wardrobe (mass 100 kg, height 4 m, width 2 m, depth 1 m), symmetric about the Y-Y axis, stands on a rough level floor as shown in the figure. A force P is applied at mid-height on the wardrobe so as to tip it about point Q without slipping. What are the minimum values of the force (in Newton) and the static coefficient of friction μ between the floor and the wardrobe, respectively?

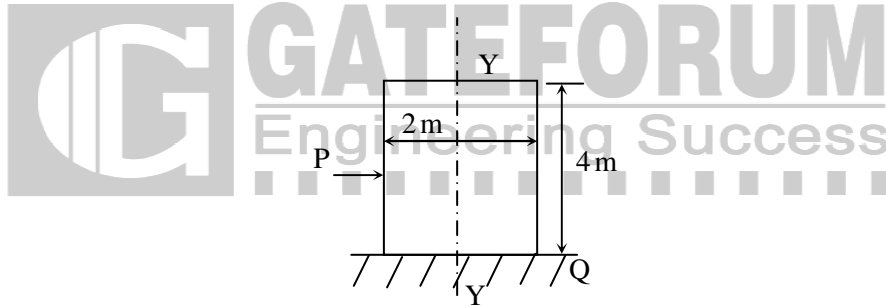

- (A) 490.5 and 0.5
(B) 981 and 0.5
(C) 1000.5 and 0.15
(D) 1000.5 and 0.25

Answer: (A)

Exp: Taking moments about Q, $\sum M_Q = 0$

$\Rightarrow W \times 1m = P \times 2m$

$\Rightarrow P = \frac{100 \times 9.81}{2} = 490.5 \text{ N}$

$\sum H = 0$

$\Rightarrow F_f = P = 490.5 \text{ N}$

$\sum V = 0 \Rightarrow R_N = mg = 981 \text{ N}$

Friction Force = μR_N

$\mu = \frac{490.5}{981} = 0.5$

38. Torque and angular speed data over one cycle for a shaft carrying a flywheel are shown in the figures. The moment of inertia (in kg.m²) of the flywheel is _____

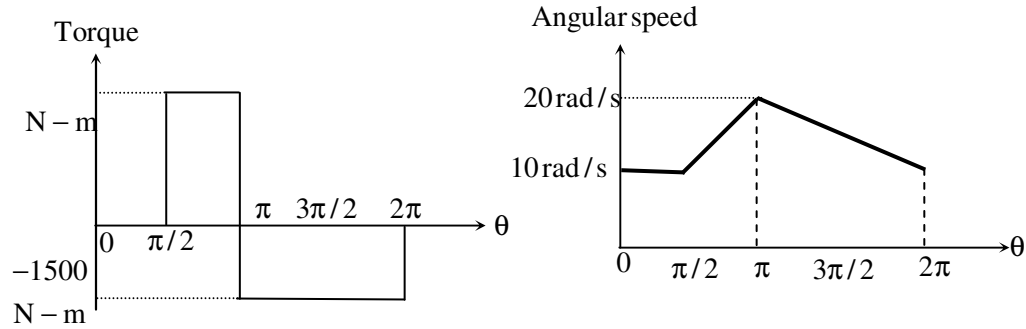

Answer: 30 to 32

$$\text{Exp: } \omega = \frac{\omega_{\max} + \omega_{\min}}{2} = \frac{20 + 0}{2} = 10$$

$$C_s = \frac{\omega_{\max} - \omega_{\min}}{\omega} = \frac{20 - 0}{10} = 2$$

$$\Delta E = \text{Area of } T - \theta \text{ diagram} = \frac{\pi}{2} \times 3000 + 1500 \times \pi = 3000\pi$$

$$\Delta E = I\omega^2 C_s$$

$$\Rightarrow 3000\pi = I(10)^2 \times 2$$

$$\Rightarrow I = 47.12$$

39. A single degree of freedom system has a mass of 2 kg, stiffness 8 N/m and viscous damping ratio 0.02. The dynamic magnification factor at an excitation frequency of 1.5 rad/s is _____

Answer: 2.0 to 2.4

$$\text{Exp: } \text{Damping ratio} = 0.02 = \frac{C}{2m\omega_n} = \frac{C}{2 \times 2 \times \sqrt{\frac{8}{2}}}$$

$$\Rightarrow C = 0.02 \times 2 \times 2 \times \sqrt{\frac{8}{2}} = 0.32$$

$$\text{Dynamic magnification factor} = \frac{1}{\sqrt{\frac{c^2 \omega^2}{s^2} + \left(1 - \frac{\omega^2}{\omega_n^2}\right)^2}}$$

$$= \frac{1}{\sqrt{\frac{(0.32)^2 \times (1.5)^2}{(8)^2} + \left[1 - \frac{(1.5)^2}{(1)^2}\right]^2}} = 0.799$$

40. A ladder AB of length 5 m and weight (W) 600 N is resting against a wall. Assuming frictionless contact at the floor (B) and the wall (A), the magnitude of the force P (in Newton) required to maintain equilibrium of the ladder is _____

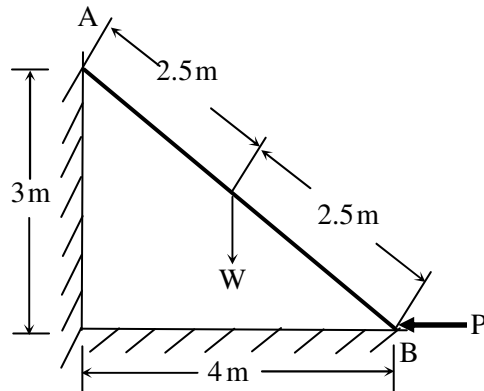

Answer: 399 to 401

Exp: Taking moments about B

$$\sum M_B = 0$$

$$\Rightarrow W \times 2 = R_A \times 3$$

$$\Rightarrow R_A = \frac{600 \times 2}{3} = 400$$

$$\sum H = 0 \Rightarrow R_A = P = 400 \text{ N}$$

41. A closed system contains 10 kg of saturated liquid ammonia at 10°C . Heat addition required to convert the entire liquid into saturated vapour at a constant pressure is 16.2 MJ. If the entropy of the saturated liquid is 0.88 kJ/kg.K , the entropy (in kJ/kg.K) of saturated vapour is _____

Answer: 6.4 to 6.7

Exp: $Tds = du + pdv$ (closed system)

$$283.15 \times 10 (S_2 - S_1) = 16.2 \times 10^3$$

$$\therefore S_2 = 0.88 + \frac{16.2 \times 10^3}{283.15 \times 10} = 6.6013 \text{ kJ/kg}$$

42. A plane wall has a thermal conductivity of 1.15 W/m.K . If the inner surface is at 1100°C and the outer surface is at 350°C , then the design thickness (in meter) of the wall to maintain a steady heat flux of 2500 W/m^2 should be _____

Answer: 0.33 to 0.35

Exp: $Q = KA \frac{dT}{dx}$

$$q = \frac{Q}{A} = 2500 \text{ W/m}^2$$

$$2500 = K \frac{dT}{dx}$$

$$2500 = 1.15 \times \frac{(1100 - 350)}{x}$$

$$x = 0.345 \text{ m.}$$

43. Consider the following statements regarding streamline(s):
- (i) It is a continuous line such that the tangent at any point on it shows the velocity vector at that point
 - (ii) There is no flow across streamlines
 - (iii) $\frac{dx}{u} = \frac{dy}{v} = \frac{dz}{w}$ is the differential equation of a streamline, where u, v and w are velocities in directions x, y and z , respectively
 - (iv) In an unsteady flow, the path of a particle is a streamline
- Which one of the following combinations of the statements is true?
- (A) (i), (ii), (iv) (B) (ii), (iii), (iv) (C) (i), (iii), (iv) (D) (i), (ii), (iii)

Answer: (D)

44. Consider a velocity field $\vec{V} = K(\hat{y}i + x\hat{k})$, where K is a constant. The vorticity, Ω_z , is
- (A) - K (B) K (C) - $K/2$ (D) $K/2$

Answer: (A)

Exp: $\Omega_z = \frac{\partial v}{\partial x} - \frac{\partial u}{\partial y}$

$(v=0)$
 $\therefore \Omega_z = -\frac{\partial(ky)}{\partial y} = -k.$



45. Water flows through a tube of diameter 25 mm at an average velocity of 1.0m/s. The properties of water $\rho = 1000\text{kg/m}^3, \mu = 7.25 \times 10^{-4} \text{ N.s/m}^2, k = 0.625 \text{ W/mK}, Pr = 4.85$. Using $Nu = 0.023Re^{0.8} Pr^{0.4}$, the convective heat transfer coefficient (in $\text{W/m}^2.\text{K}$) is _____

Answer: 4600 to 4625

Exp: $Re = \frac{\rho VD}{\mu} = \frac{1000 \times 1 \times 25 \times 10^{-3}}{7.25 \times 10^{-4}} = 34482.758$

$Pr = 4.85$

$Nu = 0.023 Re^{0.8} Pr^{0.4} = 184.5466 = \frac{hD}{k}$

$\therefore h = \frac{184.5466 \times 0.625}{25 \times 10^{-3}} = 4613.6659 \text{ W/m}^2\text{k}.$

46. Two identical metal blocks L and M (specific heat = 0.4 kJ/kg.K), each having a mass of 5 kg, are initially at 313 K. A reversible refrigerator extracts heat from block L and rejects heat to block M until the temperature of block L reaches 293 K. The final temperature (in K) of block M is _____

Answer: 333 to 335

Exp: Given $m_1 = m_2 = 5\text{Kg}$

$$c_1 = c_2 = 0.4 \text{ KJ / Kg.K}$$

$$T_{L,i} = T_{M,i} = 313 \text{ K}$$

$$T_{M,f} = 293 \text{ K}, T_{L,f} = ?$$

$$m_1 c_1 \Delta T_1 = m_2 c_2 \Delta T_2$$

$$\Delta T_1 = \Delta T_2$$

$$T_{L,i} - T_{L,f} = T_{M,i} - T_{M,f}$$

$$313 - T_{L,f} = 313 - 293$$

$$T_{L,f} = 333 \text{ K}$$

47. Steam with specific enthalpy (h) 3214 kJ/kg enters an adiabatic turbine operating at steady state with a flow rate 10 kg/s. As it expands, at a point where h is 2920 kJ/kg, 1.5 kg/s is extracted for heating purposes. The remaining 8.5 kg/s further expands to the turbine exit, where $h = 2374$ kJ/kg. Neglecting changes in kinetic and potential energies, the net power output (in kW) of the turbine is _____

Answer: 7580 to 7582

Exp: $\dot{w} = \dot{m}_{\text{tot}}(h_1 - h_2) + (\dot{m}_{\text{tot}} - \dot{m}_{\text{out}})(h_2 - h_3)$

$$\dot{w} = 10(3214 - 2920) + 8.5(2920 - 2374)$$

$$\dot{w} = 7581 \text{ kW}$$

48. Two infinite parallel plates are placed at a certain distance apart. An infinite radiation shield is inserted between the plates without touching any of them to reduce heat exchange between the plates. Assume that the emissivities of plates and radiation shield are equal. The ratio of the net heat exchange between the plates with and without the shield is

- (A) 1/2 (B) 1/3 (C) 1/4 (D) 1/8

Answer: (A)

Exp: $\frac{q_{\text{with shields}}}{q_{\text{without shields}}} = \frac{1}{n+1}$

here, $n = 1$

$$\therefore \frac{q}{q_{\text{without}}} = \frac{1}{2}$$

49. In a compression ignition engine, the inlet air pressure is 1 bar and the pressure at the end of isentropic compression is 32.42 bar. The expansion ratio is 8. Assuming ratio of specific heats (γ) as 1.4, the air standard efficiency (in percent) is _____

Answer: 59 to 61

Exp: compression ratio, $r_k = \frac{v_1}{v_2} = \left(\frac{p_2}{p_1}\right)^{\frac{1}{\gamma}} = (32.42)^{\frac{1}{1.4}} = 11.999.9 \approx 12$

cutoff ratio, $r_k = \frac{\text{compression ratio}}{\text{expansion ratio}} = \frac{12}{8} = 1.5$

$$\eta = 1 - \frac{1}{r_k^{\gamma-1}} \left(\frac{r_c^\gamma - 1}{\gamma(r_c - 1)} \right)$$

$$= 1 - \frac{1}{12^{0.4}} \left(\frac{(1.5)^{1.4} - 1}{1.4(1.5 - 1)} \right)$$

$\eta = 59.599\%$.

50. The precedence relations and duration (in days) of activities of a project network are given in the table. The total float (in days) of activities e and f, respectively, are

Activity	Predecessors	Duration (days)
a	-	2
b	-	4
c	a	2
d	b	3
e	c	2
f	c	4
g	d,e	5

- (A) 0 and 4 (B) 1 and 4 (C) 2 and 3 (D) 3 and 1

Answer: (B)

Exp:

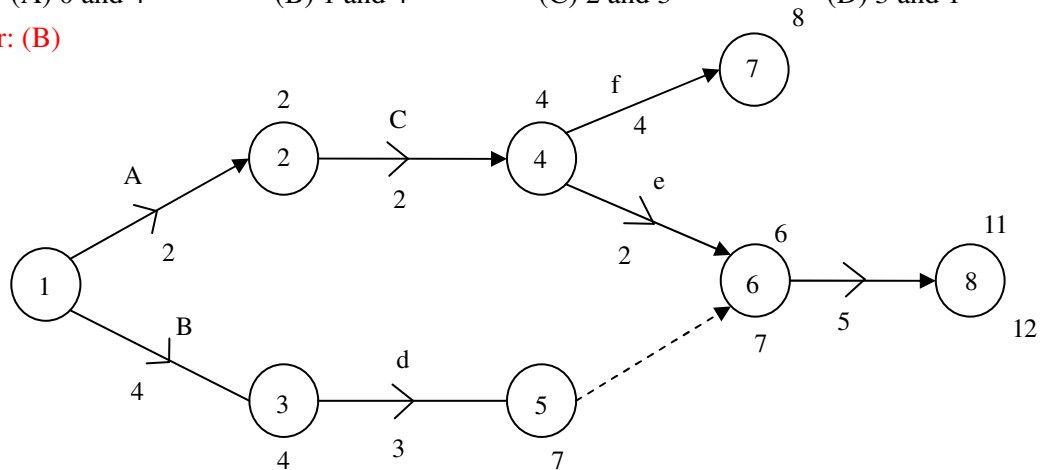

$(TF)_e = (L_j - E_i) - T_{ij} = (7 - 4) - 2 = 1$

$(TF)_f = (8 - 0) - 4 = 4$

51. At a work station, 5 jobs arrive every minute. The mean time spent on each job in the work station is 1/8 minute. The mean steady state number of jobs in the system is _____

Answer: 1.62 to 1.70

52. A GO-No GO plug gauge is to be designed for measuring a hole of nominal diameter 25 mm with a hole tolerance of ± 0.015 mm. Considering 10% of work tolerance to be the gauge tolerance and no wear condition, the dimension (in mm) of the GO plug gauge as per the unilateral tolerance system is

(A) $24.985^{+0.003}_{-0.003}$ (B) $25.015^{+0.000}_{-0.006}$ (C) $24.985^{+0.003}_{-0.003}$ (D) $24.985^{+0.003}_{-0.000}$

Answer: (D)

Exp: 25 ± 0.015

G_O-Gauge

U.L = 24.988

L.L = 24.985

$24.985^{+0.003}_{-0.000}$

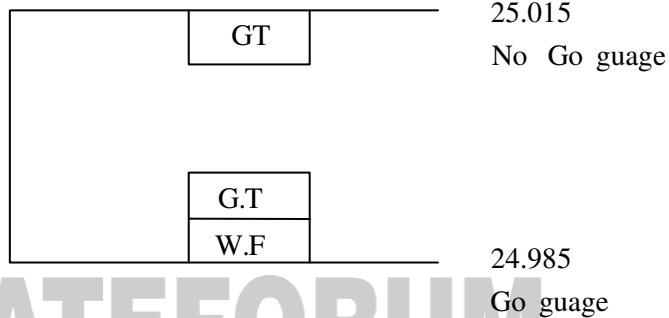

53. A cylindrical riser of 6 cm diameter and 6 cm height has to be designed for a sand casting mould for producing a steel rectangular plate casting of 7 cm \times 10 cm \times 2 cm dimensions having the total solidification time of 1.36 minute. The total solidification time (in minute) of the riser is _____

Answer: 2.5 to 4.5

54. A cast iron block of 200 mm length is being shaped in a shaping machine with a depth of cut of 4 mm, feed of 0.25 mm/stroke and the tool principal cutting edge angle of 30° . Number of cutting strokes per minute is 60. Using specific energy for cutting as 1.49 J/mm^3 , the average power consumption (in watt) is _____

Answer: 295 to 305

Exp: Specific cutting energy = $\frac{F_c}{b \times t_1} = 1.49 \text{ J/mm}^3 = \frac{F_c}{4 \times 0.25}$

$F_c = 1.49 \text{ J/mm} \cdot \text{stroke}$

$F_c = 1.49 \text{ J/mm} \times \frac{60}{\text{min}}$

$F_c = 89.4 \text{ J/mm} \cdot \text{min}$

Power = $F_c \cdot l = 89.4 \times 200 \text{ mm J/mm} \cdot \text{min} = 17880 \text{ J/min}$

Power = 298 J/S or (W).

55. A butt weld joint is developed on steel plates having yield and ultimate tensile strength of 500 MPa and 700 MPa, respectively. The thickness of the plates is 8 mm and width is 20 mm. Improper selection of welding parameters caused an undercut of 3 mm depth along the weld. The maximum transverse tensile load (in kN) carrying capacity of the developed weld joint is _____

Answer: 68 to 72

Exp: $t = 8 \text{ mm}$

$b = 20 \text{ mm}$

$d = 3 \text{ mm}$

$$\begin{aligned} \text{maximum transverse tensile load} &= \text{yield strength} \times (b - d) t \\ &= 500 \text{ N/mm}^2 \times (20 - 3) \times 8 \text{ mm}^2 \\ &= 68,000 \text{ N} \\ &= 68 \text{ kN.} \end{aligned}$$

